

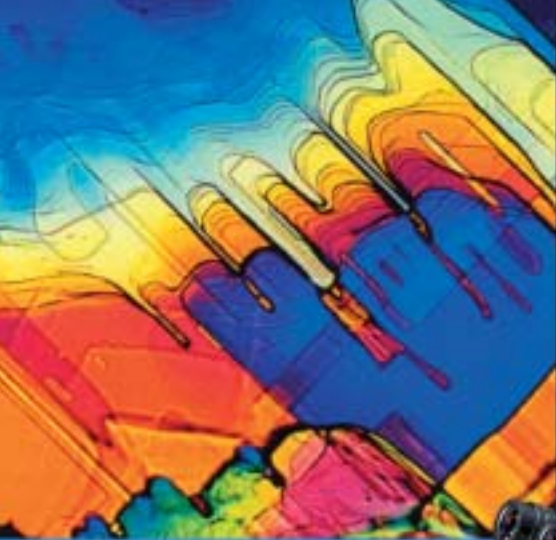

Polarizing Microscopes ECLIPSE LV100/50i

Polarizing Microscopes
ECLIPSE
LV100POL
50*i*POL





Nikon's Eclipse polarizing microscopes are already known world-wide for their clear imaging. Reengineering has now given them a new base that allows for even easier operation.

- New 50W light source is brighter than a 100W lamp. Low power consumption means little heat generation, thereby reducing the chance of heat-induced focus drift.
- Robust, vibration-resistant stage is twice as stable and durable as convention models.
- New objectives use eco-glass with no harmful substances.



Improved optics and operability for ever more demanding applications



Reversed centering quintuple nosepiece

Up to five objectives from 4x to 100x can be mounted. Provided with a DIN-compliant compensator slot, this nosepiece accepts various compensators of any make.



High-precision rotating stage (LV100POL)

The stage is large sized, pre-adjusted, and click-stops in 45° increments; therefore it is extremely accurate and easy to rotate. Because of its design—the stage is supported from the bottom of the microscope near the optical axis and incorporates steel cross roller guides—this stage is twice as stable and durable as conventional stages.



Intermediate tube

The intermediate tube incorporates a Bertrand lens, enabling both the observation and capture of conoscopic and orthoscopic images. The Bertrand lens is focusable and centerable. The slider-type analyzer is 360° rotatable.



ECLIPSE 50i POL
(Diascopic/Episcopic illumination)



ECLIPSE 50i POL
(Diascopic illumination)



ECLIPSE LV100 POL
(Diascopic/Episcopic illumination)



ECLIPSE LV100 POL
(Diascopic illumination)



Conoscopic image of mica / CFI P Achromat 40X

ECLIPSE LV100 POL Diascopic illumination type

Outstanding optical performance, perfect for a wide variety of imaging applications

Nikon has developed a new high-intensity 50W halogen light source that provides greater brightness than a 100W lamp. Brightness is increased by approximately 20 to 40% with objective magnifications of 50x and higher. This new light source consumes little power and generates very little heat, greatly reducing focus drift resulting from light source heat.

Brightness of over 100W using only 50W? How?

Brightness is not determined by wattage! Nikon's new light source achieves greater brightness by optimizing the filament and improving pupil fulfillment by optically expanding the size of the light source. This has resulted in a 50W light source that is brighter than a 100W lamp—about 20% brighter with episcopic illumination, 40% with diascopic illumination*.

*With 100x objectives.

Uniform brightness with diascopic illumination

A fly-eye lens has been employed in the diascopic illumination optics. This enables high quality digital imaging with no variations in luminescence throughout the view field.

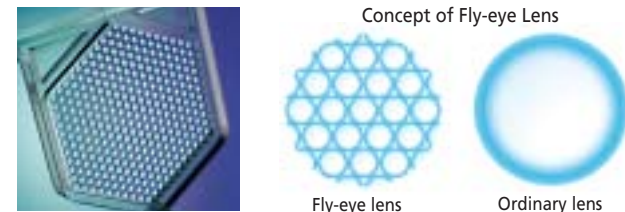

ECLIPSE LV100 POL Diascopic/Episcopic illumination type ECLIPSE 50i POL Diascopic/Episcopic illumination type

Accomplishes advanced polarizing microscopy under both diascopic and episcopic illumination

Both diascopic and episcopic polarizing observations are possible by mounting the LV-UEPI universal epi-illuminator. Switching the illumination is a breeze. The illuminator is brighter than a 100W lamp. With an optional universal-type nosepiece and DIC accessories, differential interference contrast (DIC) microscopy is also possible.



ECLIPSE 50i POL
(Diascopic/Episcopic illumination type)



ECLIPSE LV100 POL
(Diascopic/Episcopic illumination type)

ECLIPSE 50i POL Diascopic illumination type

A compact polarizing microscope that balances optical performance and usability

- Slim and compact, so it won't occupy your entire desk
- Nosepiece uses the same DIN standard compensator slot as more expensive models
- All objectives on the nosepiece are centerable
- Uses CFI60 optics, realizing both high NA and long working distance
- Clamp-type focusing mechanism makes for easy, safe specimen exchange
- Excellent cost performance balanced with superb basic performance as a polarizing microscope



Industry-acclaimed CFI60 optics objectives

Nikon's proprietary infinity optics—the CFI60 system—successfully balance long working distances and high numerical apertures, delivering tack-sharp aberration-free images regardless of magnification. The new CFI LU Plan Fluor EPI P objective series uses eco-glass that contains no harmful substances such as lead and arsenic, enabling an environmentally conscious design.



CFI P Achromat objective series (for diascopic illumination)



CFI Plan Fluor EPI P objective series (for episcopic illumination)

Accessories for Polarizing Observations

Attachable mechanical stage

To improve microscopy efficiency, an attachable mechanical stage can be mounted on the rotating stage. Cross travel: 35 x 25 mm. Min. increment: 0.1mm on the vernier



Senarmont compensator

Inserted into the intermediate tube. Besides a standard $1/4\lambda$ plate and a 546nm (1λ) tint plate (1st order red plate), a Senarmont compensator is also available as an option, for retardation measurements from 0 to 1λ .



Quartz wedge compensator

Inserted into the intermediate tube, this compensator permits retardation measurements from 1 to 6 orders.



Berek compensator

Inserted into the nosepiece slot, this compensator permits retardation measurements from 0 to 1800 nm. Manufactured by Nichika Corporation.



IF 546/12 retardation filter

High-precision interference filter with a 546nm central wavelength and 12nm full-width at half maximum. Used to increase the precision of retardation measurements.

Digital camera systems—Digital Sight series

You can select the most appropriate camera head and control unit to meet your specific needs.

High frame rate color camera head—DS-2Mv

Features a high frame rate, 2.0-megapixel color CCD. Displays SXGA live images (1600 x 1200 pixels max.) at 15fps (30fps max.). The DS-2Mv balances smooth live image movement and excellent image quality.



High frame rate cooled monochrome camera head—DS-2MBWc

Incorporates a cooling mechanism. Even faint fluorescence can be clearly captured without heat-induced noise. With sensitivity five times greater than conventional models and the high frame rate (30fps max.) of the 2.0-megapixel monochrome CCD, this camera provides clear images with minimal photobleaching.



High frame rate live display monochrome camera head—DS-2MBW

Incorporating a 2.0-megapixel monochrome CCD with sensitivity five times greater than conventional models, it has an excellent cost-to-performance ratio, with both high frame rates and high sensitivity.



High-definition color camera head—DS-5M

Ideal for brightfield, darkfield, phase contrast, and DIC applications. Its 5.0-megapixel color CCD delivers high-definition images.



High-definition cooled color camera head—DS-5Mc

Suited to weak-light applications requiring long term exposure such as epifluorescence and darkfield. A built-in cooling mechanism in the 5.0-megapixel color CCD contributes to clear images with minimal heat-induced noise.



Standalone control unit—DS-L1

A standalone type with a 6.3-in. TFT monitor and excellent extensibility thanks to analog RGB outputs and network connectivity.



PC-use control unit—DS-U1

Allows observation, image capture, measurement and analysis on a PC monitor using camera control software ACT-2U. High-speed image transfer to a PC is possible via an easily-connectable USB interface.



System Diagram

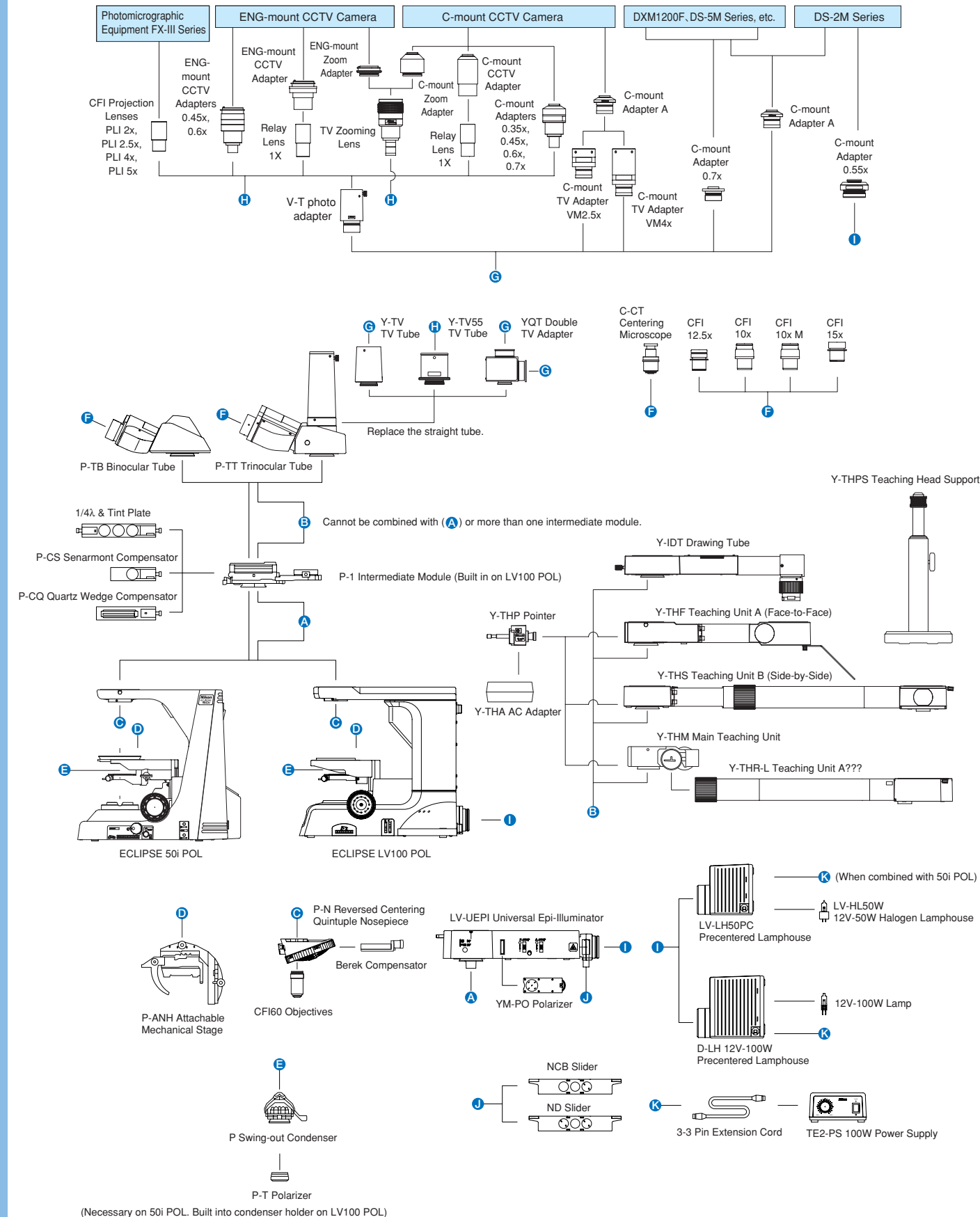

Specifications

		ECLIPSE LV100 POL	ECLIPSE 50i POL
Main body	Optical system	CFI60 infinity	
	Illumination	12V-50W halogen lamp; 12V-50W DC transformer built-in; Diascopic/episcopic illumination changeover switch; Fly-eye lens; NCB11, ND8 filters built-in; 12V-100W type optional	6V-30W halogen lamp; 6V-30W transformer built-in; ND8 filter built-in
	Focusing	Coaxial coarse/fine focus knob; Focus stroke: 30mm; Coarse: 14mm per rotation; Fine: 0.1mm; Minimum reading: in 1µm increments	Coaxial coarse/fine focus knob; Focus stroke: 30mm; Coarse: 13.8mm per rotation; Fine: 0.1mm; Minimum reading: in 1µm increments
Eyepiece		10x (F.O.V. 22mm), CM type with crosshair and micrometer scale	
Eyepiece tube		P-TT Trinocular Tube for polarizing microscopy; P-TB Binocular Tube for polarizing microscopy	
Intermediate tube		Built-in focusable Bertrand lens removable from optical path; Conoscopic/Orthoscopic observations switchable; Analyzer built-in; Plate/compensator slot	
Analyzer		360° rotary dial; Minimum reading angle 0.1°	
Nosepiece		Reversed centering quintuple nosepiece (detachable); DIN slot	
Stage		Top-grade dedicated circular graduated stage Rotatable 360° horizontally; can be fixed at a specific position; Graduated 360° (in 1° increments) Mechanical stage attachable: 35 x 25 mm travel; vernier 0.1mm	Ball bearing rotary stage; Rotatable 360° horizontally; can be fixed at a specific position; Graduated 360° (in 1° increments); Mechanical stage attachable: 35 x 25 mm travel; vernier 0.1mm
Condenser		Dedicated strain-free swing-out type; P Achromat N.A. 0.9	
Polarizer		Fixed to the bottom of the condenser holder; Scale	No scale
Objectives		CFI P Achromat 4x, 10x, 20x, 40x, 100x CFI LU Plan Fluor Epi P 5x, 10x, 20x, 50x, 100x	
Episcopic illuminator		LV-UEPI Universal Epi-illuminator*	
Compensators		Standard 1/4λ & tint plate, quartz wedge or Senarmont compensator can be inserted into intermediate tube slot	
Power consumption		1.2A/75W	0.9A/48W
Weight		Approx. 17kg (standard binocular set)	Approx. 14kg (standard binocular set)

* The ECLIPSE LV100 POL accommodates a 12V-50W illumination transformer, while the 50i POL requires an external power supply.

Dimensional Diagram

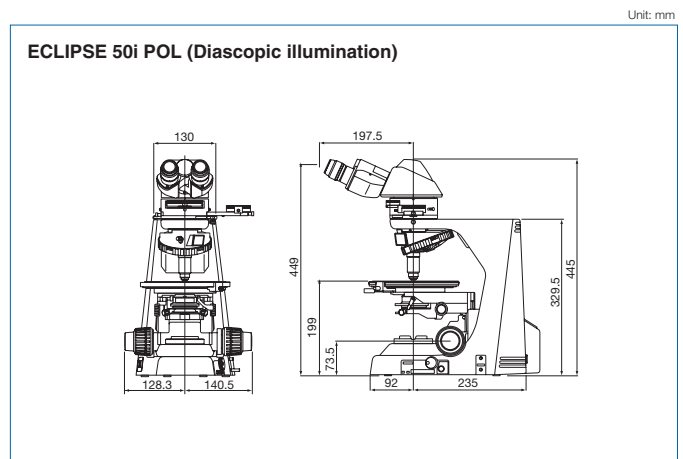
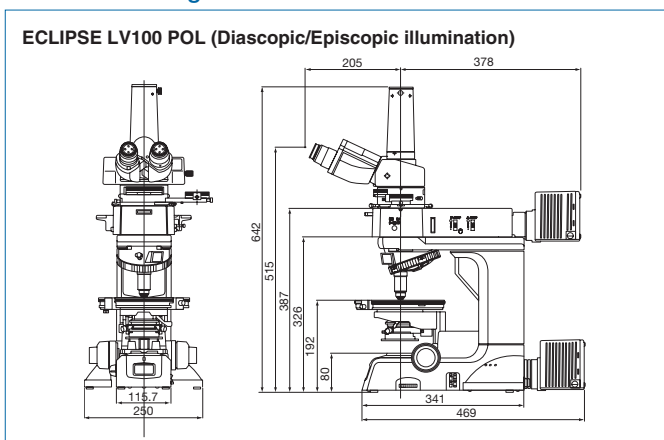

Specifications and equipment are subject to change without any notice or obligation on the part of the manufacturer. August 2005 ©2005 NIKON CORPORATION



* Monitor images are simulated.

Company names and product names appearing in this brochure are their registered trademarks or trademarks.



ISO 14001 Certified
NIKON INSTRTECH CO., LTD.



ISO 9001 Certified
NIKON CORPORATION
Instruments Company



ISO 14001 Certified
NIKON CORPORATION
Yokohama Plant

NIKON INSTRTECH CO., LTD.

Parale Mitsui Bldg., 8, Higashida-cho, Kawasaki-ku,
Kawasaki, Kanagawa 210-0005, Japan
phone: +81-44-223-2168 fax: +81-44-223-2182
www.nikon-instruments.jp/eng/

NIKON INSTRUMENTS (SHANGHAI) CO., LTD.

CHINA phone: +86-21-5836-0050 fax: +86-21-5836-0030
(Beijing office)
CHINA phone: +86-10-5869-2255 fax: +86-10-5869-2277

NIKON SINGAPORE PTE LTD

SINGAPORE phone: +65-6559-3618 fax: +65-6559-3668

NIKON MALAYSIA SDN. BHD.

MALAYSIA phone: +60-3-78763887 fax: +60-3-78763887

NIKON INSTRUMENTS KOREA CO., LTD.

KOREA phone: +82-2-2186-8410 fax: +82-2-555-4415

NIKON INSTRUMENTS EUROPE B.V.

P.O. Box 222, 1170 AE Badhoevedorp, The Netherlands
phone: +31-20-44-96-222 fax: +31-20-44-96-298
www.nikon-instruments.com/

NIKON FRANCE S.A.S.

FRANCE phone: +33-1-45-16-45-16 fax: +33-1-45-16-00-33

NIKON GMBH

GERMANY phone: +49-211-9414-0 fax: +49-211-9414-322

NIKON INSTRUMENTS S.p.A.

ITALY phone: +39-55-3009601 fax: +39-55-300993

NIKON AG

SWITZERLAND phone: +41-43-277-2860 fax: +41-43-277-2861

NIKON UK LTD.

UNITED KINGDOM phone: +44-20-8541-4440 fax: +44-20-8541-4584

NIKON INSTRUMENTS INC.

1300 Walt Whitman Road, Melville, N.Y. 11747-3064, U.S.A.
phone: +1-631-547-8500; +1-800-52-NIKON (within the U.S.A. only) fax: +1-631-547-0306
www.nikonusa.com/

NIKON CANADA INC.

CANADA phone: +1-905-625-9910 fax: +1-905-625-0103



NIKON CORPORATION

Fuji Bldg., 2-3, Marunouchi 3-chome, Chiyoda-ku,
Tokyo 100-8331, Japan
www.nikon.com/